



YRSF-2420-31DC/I/KL

SFP 1.25Gb/s 20km Transceiver with DDMI

Hot Pluggable, 1310nm with LC Receptacle

● Features:

- Data-rate of 1.25Gbps operation
- 1310nm FP Laser Transmitter and PIN-TIA Receiver
- Compliant with SFP MSA and SFF-8472 with duplex LC receptacle
- 10km transmission with 9/125 μ m SMF
- Hot-Pluggable Capability with SFP form factor
- Single +3.3V Power Supply
- Operating Case Temperature:
Standard: 0°C ~+70°C
Industrial: -40°C~+85°C
Exceptional: -40°C~+105°C
- Compatible with RoHS

● Applications:

- Gigabit Ethernet Switches and Routers
- Fiber Channel Switch Infrastructure
- Other optical links

YRSF-2420-31DC/I/KL transceiver is small form factor pluggable module for double fiber optical data communications. It's RoHS compliant and lead-free per Directive 2002/95/EC. The digital diagnostics functions are compliant with SFF-8472, which are available via the 2-wire serial bus specified in the SFP MSA.

● Order Information:

Part No.	Bit Rate (Gbps)	Laser(n m)	Distance [note2]	Fiber Type	DDMI	Connector	Temp [note1]
YRSF-2420-31DCL	1.25	1310	20km	SMF	YES	LC	0°C~+70°C
YRSF-2420-31DIL	1.25	1310	20km	SMF	YES	LC	-40°C~+85°C
YRSF-2420-31DKL	1.25	1310	20km	SMF	YES	LC	-40°C~+105°C

Notes:

- 1.Case Temperature.
- 2.Maximum Supported Distances.



● Absolute Maximum Ratings:

Parameter	Symbol	Min.	Typ	Max.	Unit
Maximum Supply Voltage	Vcc	-0.5	-	4.0	V
Storage Temperature	TS	-40	-	105	°C
Operating Humidity	-	5	-	95	%

● Recommended Operating Environment:

Parameter	Symbol	Min.	Typ	Max.	Unit
Power Supply Voltage	Vcc	3.13	3.30	3.47	V
Power Supply Current	Icc	-	-	300	mA
Surge current	I _{surge}	-	-	30	mA
Case Operating Temperature	YRSF-2420-31DCL	0	-	+70	°C
	YRSF-2420-31DIL	-40	-	+85	°C
	YRSF-2420-31DKL	-40	-	+105	°C
Data Rate	DR	-	1.25	-	Gbps

● Transmitter Electrical and Optical Characteristics:(Condition: T_a=T_{OP})

Parameter	Symbol	Min.	Typ	Max.	Unit
Center Wavelength	λ_c	1260	1310	1360	nm
Output Spectral Width	$\Delta\lambda(\text{RMS})$	-	-	4	nm
Average Output Power	P _o	-9.0	-	-3.0	dBm
Extinction Ratio	ER	9	-	-	dB
Output Optical Eye	IEEE802.3z and ANSI Fiber Channel Compliant				
Average Launch power of OFF TX	P _{off}	-	-	-30	dBm
Rise/Fall Time (20%~80%)	T _r /T _f	-	-	260	ps
Transmitter Differential Input Volt	+/-TX_DAT	400	-	1800	mV _{p-p}
Tx_Disable Input Voltage – Low	V _{IL}	0	-	0.8	V
Tx_Disable Input Voltage – High	V _{IH}	2.0	-	Vcc	V
Tx_Fault Output Voltage – Low	V _{OL}	0	-	0.8	V
Tx_Fault Output Voltage – High	V _{OH}	2.4	-	Vcc	V

● Receiver Electrical and Optical Characteristics:(Condition: T_a=T_{OP})

Parameter	Symbol	Min.	Typ	Max.	Unit
Operating Wavelength	λ_c	1260	1310	1610	nm
Receive Sensitivity(Note 1)	P _{min}	-	-	-22	dBm
Maximum Input Power(Note 1)	P _{MAX}	0.5	-	-	dBm
LOS Assert	LOSA	-30	-	-	dBm



LOS De-assert	LOSD	-	-	-23	dBm
LOS Hysteresis	-	0.5	-	4	dB
Output High Voltage	V _{OH}	V _{CC} -1.03	-	V _{CC} -0.89	V
Output Low Voltage	V _{OL}	V _{CC} -1.82	-	V _{CC} -1.63	V
Receiver Differential Output Volt	+/-RX_DAT	400	-	1800	mV p-p
Rx_LOS Output Voltage- Low	V _{OL}	0	-	0.8	V
Rx_LOS Output Voltage- High	V _{OH}	2.0	-	V _{CC}	V

Note:

1. Measured with a PRBS 2⁷ -1 test pattern @1250Mbps, BER ≤1×10⁻¹².

● **Block Diagram of Transceiver:**

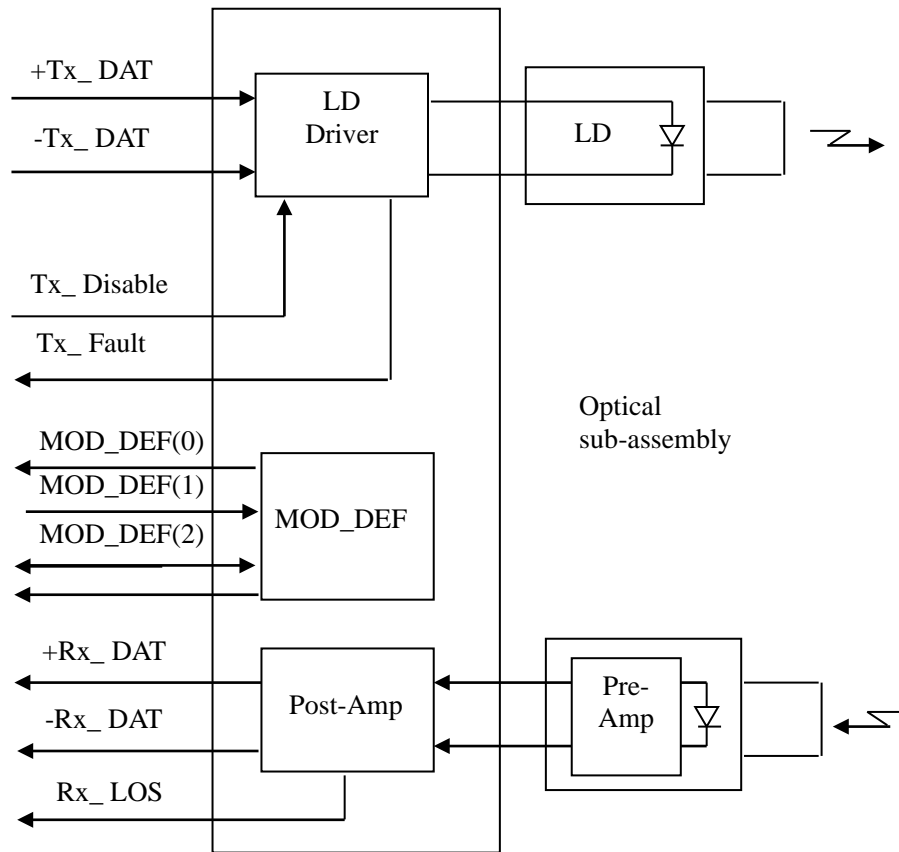



● **Pin Assignment:**

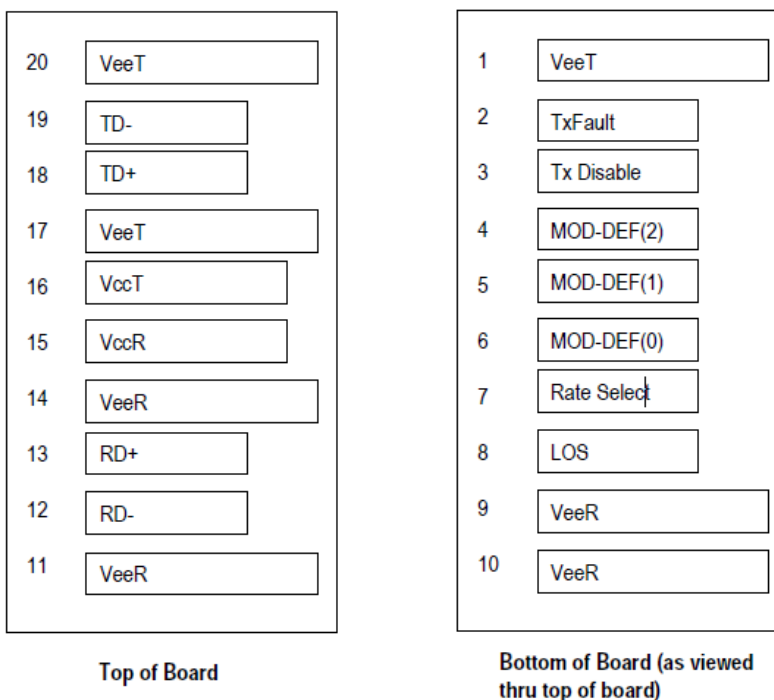

Pin out of Connector Block on Host Board

● **Pin Description:**

Pin	Symbol	Name/Description	Notes
1	VEET	Module Transmitter Ground	1
2	TX_FAULT	Module Transmitter Fault	2
3	TX_DISABLE	Transmitter Disable; Turns off transmitter laser output	3
4	MOD-DEF2	2-Wire Serial Interface Data Line (MOD-DEF2)	2
5	MOD-DEF1	2-Wire Serial Interface Clock (MOD-DEF1)	2
6	MOD-DEF0	Module Absent, connected to VEET or VEER in the module	
7	Rate Select	Not connect	
8	LOS	Loss of Signal	2
9	VEER	Module Receiver Ground	
10	VEER	Module Receiver Ground	1
11	VEER	Module Receiver Ground	1
12	RD-	Receiver Inverted Data Output	
13	RD+	Receiver Non-Inverted Data Output	
14	VEER	Module Receiver Ground	1
15	VCCR	Module Receiver 3.3 V Supply	



16	VCCT	Module Transmitter 3.3 V Supply	
17	VEET	Module Transmitter Ground	1
18	TD+	Transmitter Non-Inverted Data Input	
19	TD-	Transmitter Inverted Data Input	
20	VEET	Module Transmitter Ground	1

Notes:

1. Module circuit ground is isolated from module chassis ground within the module.
2. Should be pulled up with 4.7kΩ to 10kΩ ohms on host board to a voltage between 3.15V and 3.6V.
3. Tx_Disable is an input contact with a 4.7 kΩ to 10 kΩ pullup to VccT inside the module.

● **Mechanical Dimensions:**

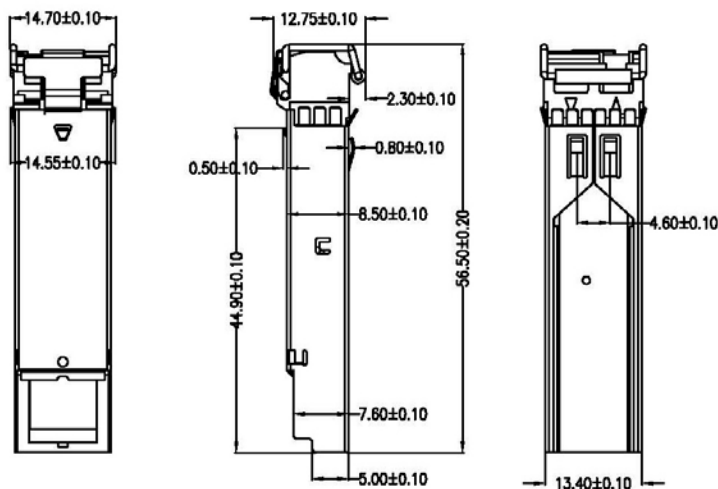
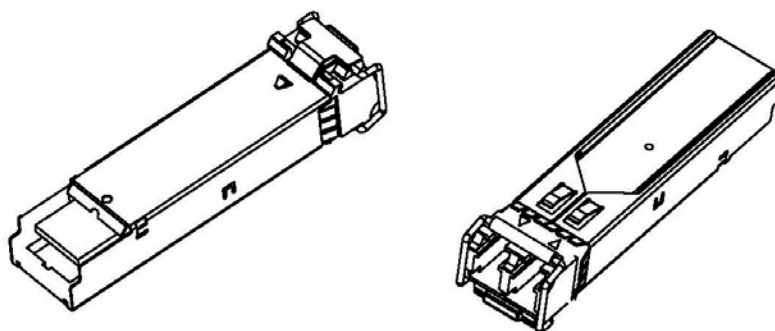

NOTE:

- | | | | |
|----|-------------|----------|------------|
| 1. | DESCRIPTION | MATERIAL | PLATING |
| 01 | SFP BASE | ZIN | Ni FOR ALL |
| 02 | SFP SHELL | SPCC | Ni FOR ALL |
2. TEMPERATURE:
OPERATION: -40°C ~ +85°C
STORAGE: -40°C ~ +85°C
 3. RoHS COMPLIANT
 4. PART NUMBER : SFP001SH

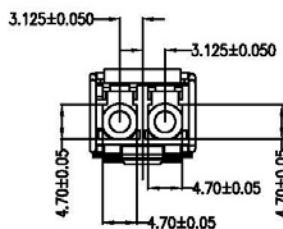



● Recommended Circuit:

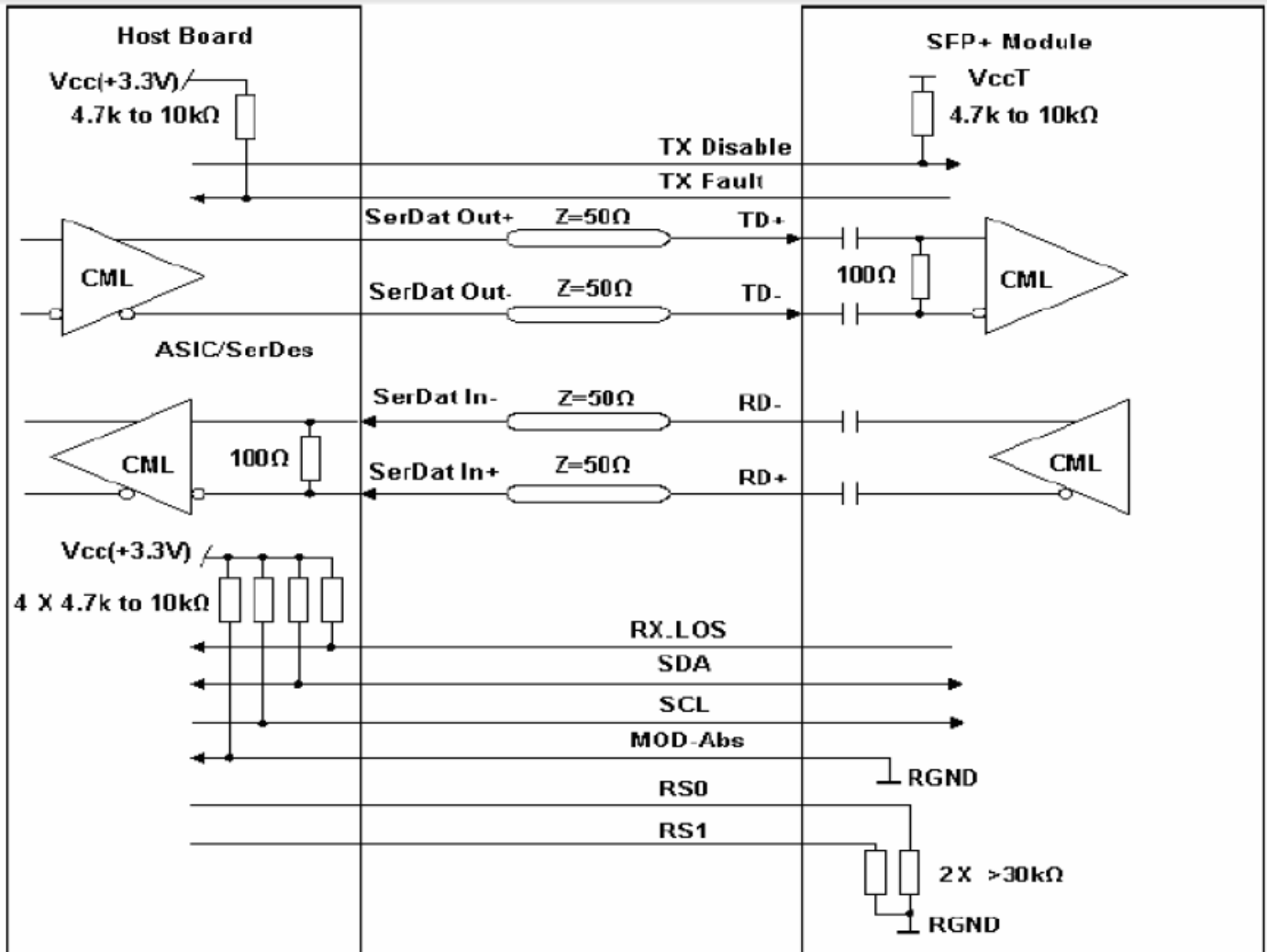



● Digital Diagnostic Functions

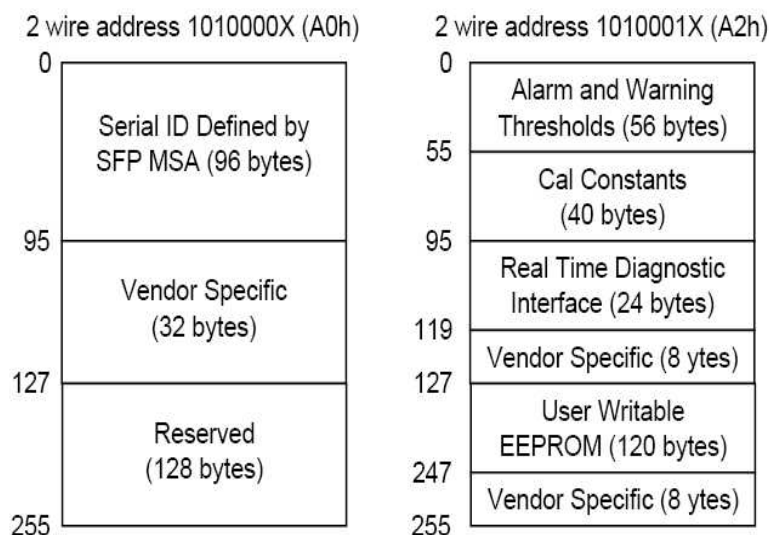

YRSF-2420-31DC/I/KL SFP transceiver supports the 2-wire serial communication protocol as defined in SFP MSA: in which defines a 256-byte memory map in EEPROM at 8 bit address 1010000X (A0h). The digital diagnostic monitoring interface be assigned with 8 bit address 1010001X (A2h)

Additionally, SFP transceivers provide a unique digital diagnostic monitoring interface (DDMI), which allows real-time access to product operating parameters such as transceiver supply voltage, transceiver temperature, transmitted optical power, laser bias current and received optical power. It also defines alarm and warning threshold, which alerts end-users when particular operating parameters are outside of factory setting.

When the serial protocol is activated, the serial clock signal (SCL, Mod Def 1) is generated by the host. The positive edge clocks data into those segments of the EEPROM that are not write-protected. The negative edge clocks data from the SFP transceiver. The serial data signal (SDA, Mod Def 2) is bi-Directional for serial data transfer. The host uses SDA in conjunction with SCL to mark the start and end of serial protocol activation. The memories are organized as a series of 8-bit data words that can be addressed individually or sequentially.

Digital diagnostics for the YRSF-2420-31DC/I/KL are internally calibrated by default: Calibration and alarm/warning threshold data is written during device manufacturing.

● Digital Diagnostic Specifications

YRSF-2420-31DC/I/KL transceivers have internally calibrated digital diagnostics.

Monitor accuracy					
Parameter	Min	Typ	Max	Units	Ref
Internally measured transceiver temperature			±3	°C	
Internally measured transceiver supply voltage			±3	%	
Measured TX bias current			±10	%	
Measured TX output power			±3	dB	
Measured RX received average optical power			±3	dB	